

2025

Playstation Kiosks

INSTALLATION AND USER INSTRUCTIONS











Contents



Amusement Connect Paystation Kiosk Owner’s Manual	1
Parts List.....	4
Kiosk Device and Cabling Color Code.....	7
Voltages	8
Initial Kiosk Start Up.....	9
Powering on the Kiosk PC	9
Kiosk Settings	11
Log In.....	11
Screen Navigation	11
Collection	12
Change Secondary Language	13
Enabling/Disabling Devices and Settings	14
Closing, Restarting or Shutting Down the Kiosk	14
Getting to the Kiosk Desktop	15
Finding the On-Screen Keyboard	15
Installing Team Viewer	16
Determining Network Connection Type	17
Enable DHCP Settings	18
Starting the Kiosk Application from the Desktop	19
Mounting Kiosk to the Floor	20
Credit Card Device	20
Enabling Credit Card Device.....	20
Alert Eruption	21
Cleaning	21
Card Dispenser	22
Loading.....	22
Testing.....	22
Maintenance.....	23
Sensor Cleaning	23
Adjusting the Card Thickness Gauge	25
Adjusting the Card Dispenser Belt.....	26
Record Retention: UNCONTROLLED WHEN PRINTED	2

RFID Card Scanner.....	28
Testing RFID Card Scanner	28
Configuring the RFID Card Scanner.....	28
Bill Validator.....	30
Enable Bill Validators	30
Pyramid Configuration Card	31
Configuring Pyramid Validator.....	31
Configuring Pyramid Validator - Canadian	32
Cleaning and Care - Abridged	32
Required Equipment, Tools and Supplies.....	32
Special Note:	33
Bill Acceptor Not Lighting Up or Powering On.....	33
Bill Acceptor Not Taking Bills	33
Cleaning and Care - Full	34
Required Equipment, Tools and Supplies.....	34
Cleaning Instructions.....	35
Of Special Note: Sidescan, grey lenses and cash box sensor.....	41
Troubleshooting.....	42

Parts List

Name	Part	Qty
Kiosk PC (Ace PC or Minix or BMAX)		1
Non-powered USB Hub		1
Switch (Do not power Wireless Access Points from here)		1
Power Strip		1

<p>Card Dispenser</p>				<p>1 or 2</p>
<p>Bill Validator</p>				<p>1 or 2</p>
<p>RFID Card Scanner</p>				<p>1</p>
<p>Credit Card Device</p>				<p>1</p>

Kiosk Lock And Door Release (Side of Kiosk)			1
Card Dispenser Exit			1

Kiosk Device and Cabling Color Code

Yellow – Bill Validator #1 / Blue – Bill Validator #2.



Green – Card Dispenser.



Silver – RFID Reader.

Record Retention:

UNCONTROLLED WHEN PRINTED



White - Monitor.



Red – Credit Card Device.



Voltages

Record Retention:

UNCONTROLLED WHEN PRINTED

The kiosk voltage is 110V, 2A peak. The peripherals in the kiosk require various voltages:

Bill Validators – 110V AC to power adapter

Card Dispenser – 24v Power Adapter

Credit Card Reader – 5v from PC

USB Reader – 5v from PC

Initial Kiosk Start Up

1. From the LAN port of the Subnet Router, run a CAT5 cable to the network port on the PC. If needed, the CAT5 can be connected to the Network Switch within the kiosk.
2. Power on the kiosk using the power switch located on the back side of the kiosk.



3. After the kiosk has powered on, contact Amusement Connect Customer Support at (833) 727-2233.

Powering on the Kiosk PC

In the event the kiosk PC does not turn on after a power cycle, the PC can be manually turned on.

1. Open the kiosk door.
2. Locate the PC (AcePC, BMAX or Minix).
3. Press the power button on the side of the PC. If successful, the PC will power on and a blue light will be visible.



Kiosk Settings

Log In

1. Enter Kiosk Settings by tapping the Software Version (V5.X.X.XX) on top right side of screen 11 times. Once complete a Password box will appear on the screen.



2. Enter the Kiosk Password, which is "kiosk@846" by default. If unsure, Login into the WebApp>Location Wizard>Select Location>Click "Kiosks">Find Kiosk Password on the right.

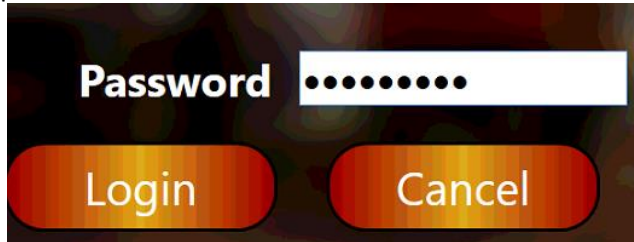

Screen Navigation

Once logged into the kiosk, you will be taken to the setting screen.

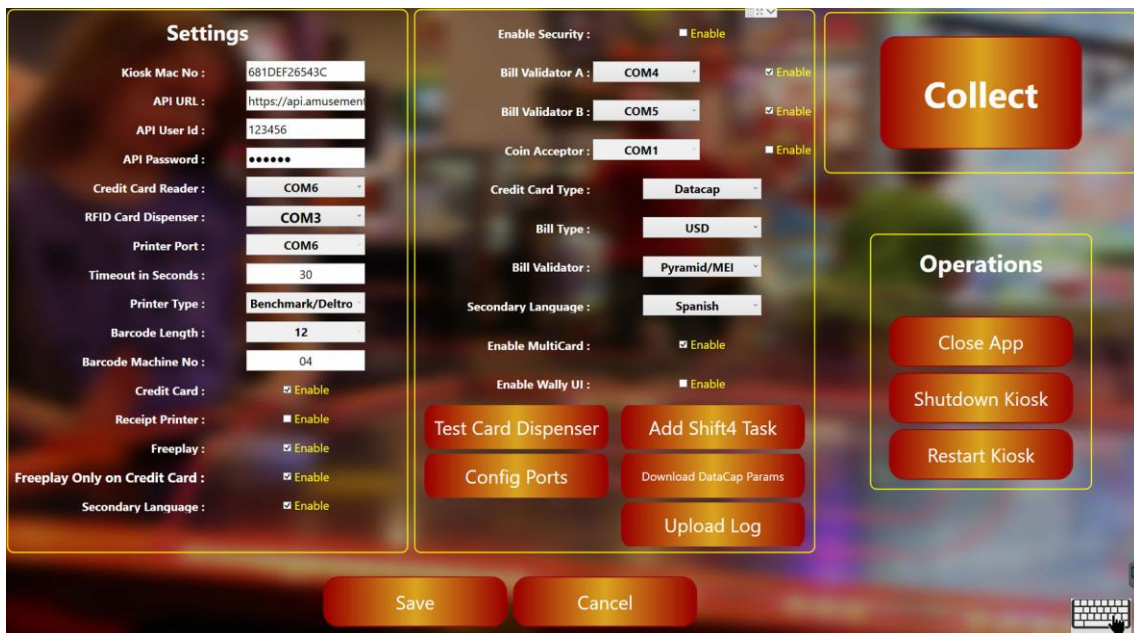

Screen Navigation Definitions

Kiosk Mac No – Mac ID of the kiosk. Do not change.	Coin Acceptor - Reserved for future development.
API URL – API location. Do not change.	Credit Card Type – Credit card gateway selection.
API User ID – User ID for the API. Do not change.	Bill Type – Currency type accepted at the kiosk.
API Password – Password for the API. This is not the password for the kiosk. Do not change.	Bill Validator – Bill Validator type selection.
Credit Card Reader – Com port setting for the credit card device.	Secondary Language – Secondary language offered at the kiosk.
RFID Card Dispenser – Com port setting for the card dispenser.	Enable Multicard – Enable/Disable the ability to sell multiple cards at once.
Printer Port – Com port setting for optional kiosk receipt printer.	Enable Wally UI – Enables Wally interface. Do not change.
Timeout in Seconds – Deration setting before the kiosk will ask the user if they want to continue with the transaction.	Test Card Dispenser – Brings up the Card Dispenser testing screen.
Printer Type – Type of optional receipt printer.	Configure Ports – Scans the Kiosk PC and displays the Com Port of each device.
Barcode Length – Barcode settings for interface with Tickets to Prizes machine. Do not change.	Add Shift4 Task – Do not use.
Barcode Machine No – Barcode settings for interface with Tickets to Prizes machine. Do not change.	Download Datcap Params – Do not use.
Credit Card – Enable/Disable the credit card device.	Upload Log – Uploads the kiosk log to the cloud.
Receipt Printer – Enable/Disable the optional receipt printer.	Collect – Performs a collection at the location.
Freeplay – Enable/Disable freeplay sales on the kiosk (if programmed in Location Wizard).	Close App – Closes the kiosk app and moved to the PC desktop.
Freeplay Only on Credit Card – Enable/Disable freeplay sales using credit card transactions only. Highly recommended to leave enabled.	Shutdown Kiosk – Powers off the kiosk.
Secondary Language – Enable/Disable the option for a secondary language button on the kiosk.	Restart Kiosk – Restarts the kiosk.
Enable Security – Allows only kiosk app to run.	Save – Saves any configuration changes made.
Bill Validator A – Com port setting for Bill Validator A. Enable/Disable Bill Validator A.	Cancel – Returns user to the main kiosk screen.
Bill Validator B - Com port setting for Bill Validator B. Enable/Disable Bill Validator B.	

Collection

1. Log into kiosk.
2. Touch the red “Collect” button on top right side of screen.

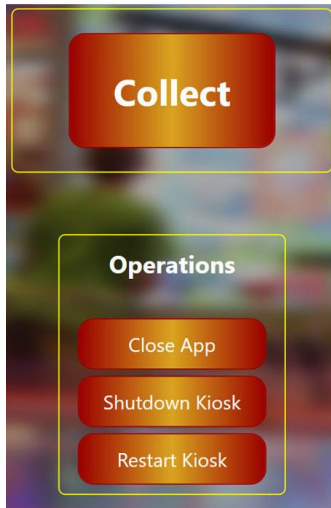

3. The collection button only needs to be hit one time per collection. If there are multiple kiosks the "Collect" button only needs to be tapped on one kiosk. Do not tap "Collect" on each Kiosk or the system will generate multiple reports.

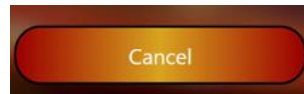

4. Click Cancel to return to Kiosk Start Screen

Change Secondary Language

1. Log into kiosk.
2. Select "Secondary Language" drop down.



3. Select desired language.
4. Touch “Save” button to save your selection
5. Touch “Cancel” to return to main screen.

Enabling/Disabling Devices and Settings

1. Log into the kiosk.
2. Locate the setting for the device or setting to be enabled/disabled (Credit Card, Bill Validator, Card Dispenser, Printer, Freeplay, Secondary Language, Multicard).
3. Touch the “Enable” box to check/uncheck.
4. Touch “Save” button to save your selection
5. Touch “Cancel” to return to main screen.

Closing, Restarting or Shutting Down the Kiosk

1. Log into the kiosk.
2. Locate the action in the “Operations” box. (Close App, Shutdown Kiosk, Restart Kiosk).

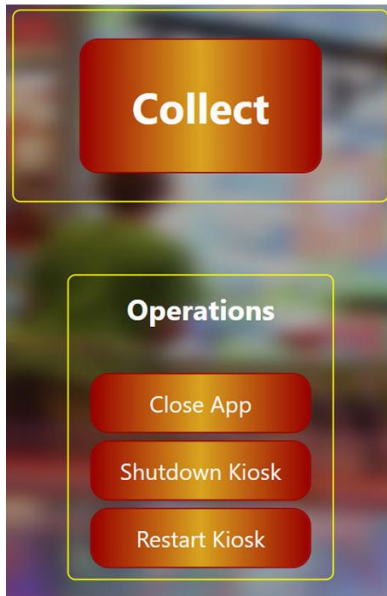

3. Touch the "Enable" box to check/uncheck.
4. Touch "Save" button to save your selection
5. Touch "Cancel" to return to main screen.

Getting to the Kiosk Desktop

1. Log into the kiosk.
2. Locate the "Close App" action in the "Operations" box.
3. Select "ok" when prompted to close the application.

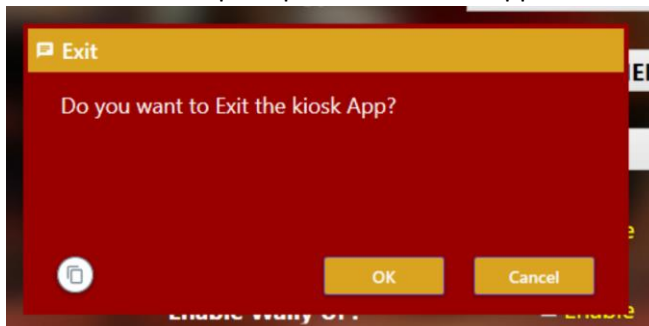

Finding the On-Screen Keyboard

1. At the desktop, open the On-screen Keyboard by touching the keyboard icon located at the bottom right corner of the screen.



2. If the keyboard icon cannot be found, press and hold on the task bar until a toolbars screen appears.

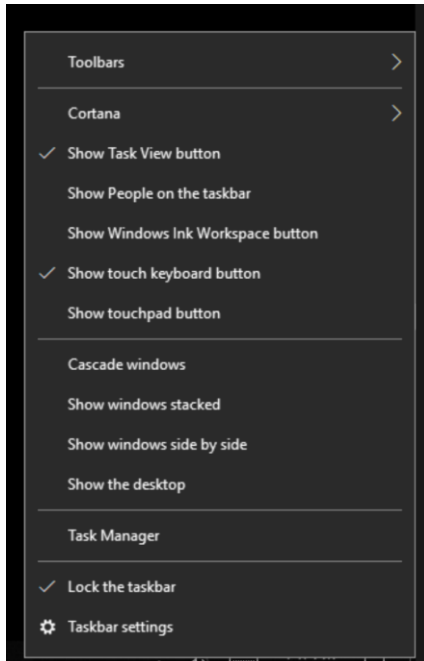

3. Select “Show touch keyboard button.”
 - a. If you cannot find the keyboard icon - Go to Start , then select Settings > Accessibility > Keyboard, and turn on the On-Screen Keyboard toggle. A keyboard that can be used to move around the screen and enter text will appear on the screen. The keyboard will remain on the screen until you close it.

Installing Team Viewer

All kiosks come from Amusement Connect with Team Viewer remotes access software installed. If, for some reason, Team Viewer needs to be added again follow these steps.

1. Exit to kiosk desktop.
2. On the desktop, open Chrome or Edge.
3. In address bar, enter www.teamviewer.com

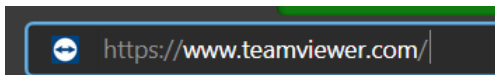

4. After the page loads, click on Download for Free.



5. Select Default installation and click “Accept – next”
6. Click “Yes” to allow the app to make changes to the device.
7. Select “I want to use the free version for personal use.”

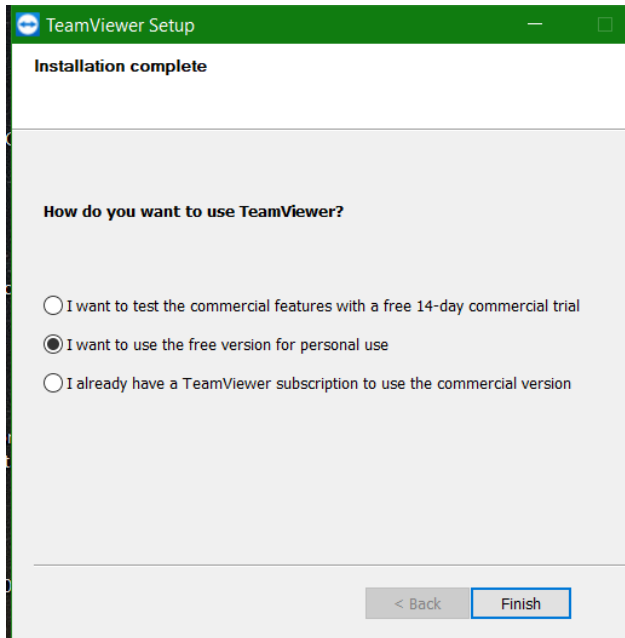

8. Once complete, record the ID and Password to allow remote control. If screen showing “Your ID and Password” is not visible, click on the “Remote Control” icon.

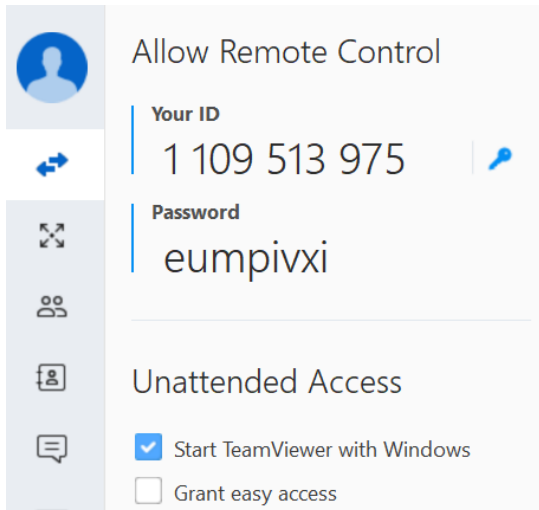

9. Contact Amusement Connect and provide Your ID and Password.

Determining Network Connection Type

1. Exit to kiosk desktop.
2. Locate the network icon at the bottom right of the screen, near the time and date. The symbol may also be found by pressing the up arrow located in the same section of the task bar.
3. If the kiosk is properly connected using the Cat5 cable the following image will be displayed.

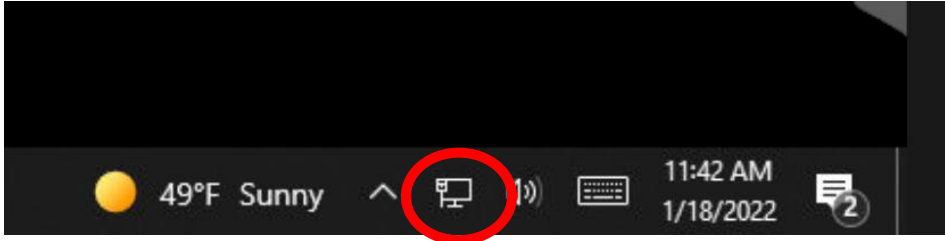

4. If the kiosk is able to connect to the internet and wired connection symbol is not present or if the wireless symbol is shown, the kiosk is running on WiFi.

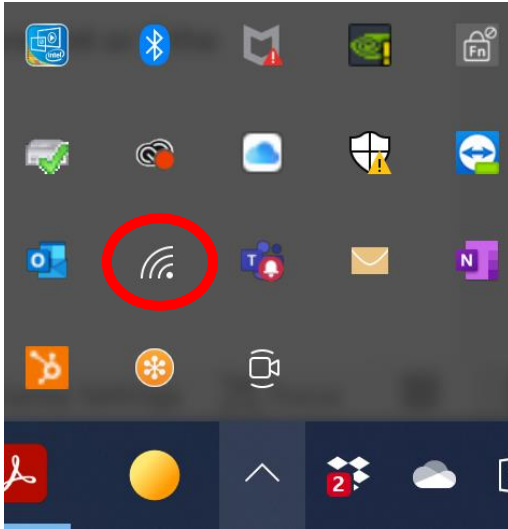

Enable DHCP Settings

1. Exit to kiosk desktop.
2. Select Start, then type settings. Select Settings > Network & internet.
3. Select Ethernet, then select the Ethernet network you're connected to and click "Properties."

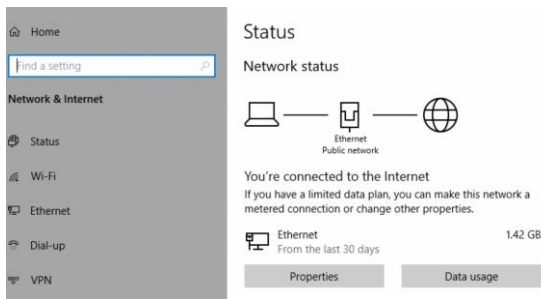

4. Find "IP settings" and click "Edit."
5. Under Edit IP settings, select Automatic (DHCP).

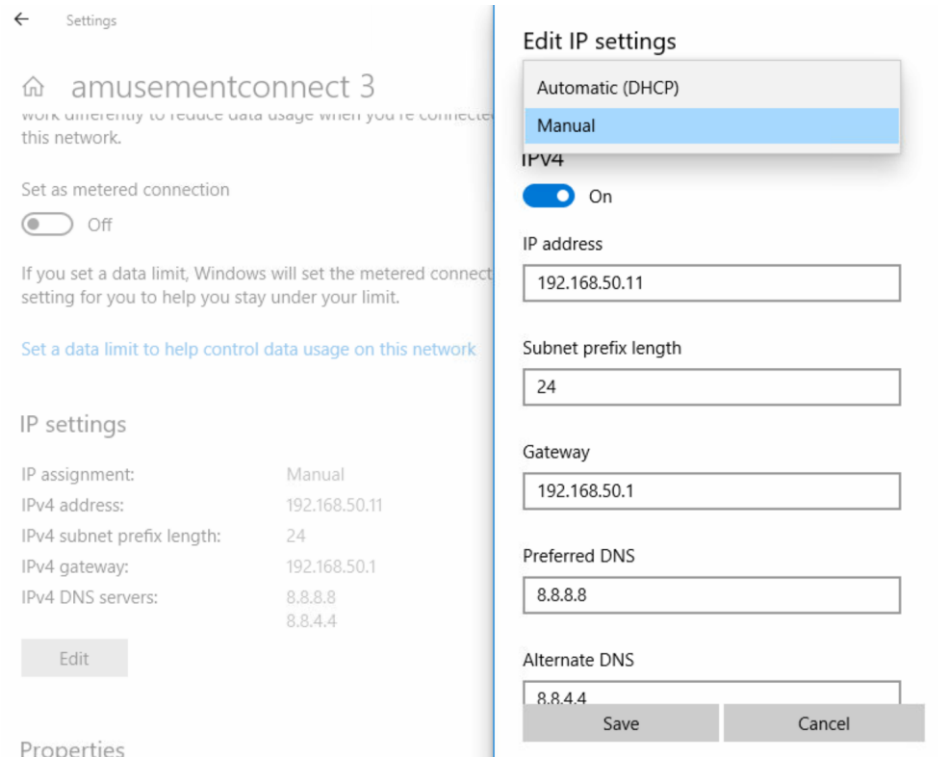

6. When you're done, select Save.

Starting the Kiosk Application from the Desktop

1. Locate the "KioskService-Shortcut" icon on the desktop.



2. Double tap the icon.
3. If successful, the Starting App screen will appear. The kiosk application will start up a few seconds later.

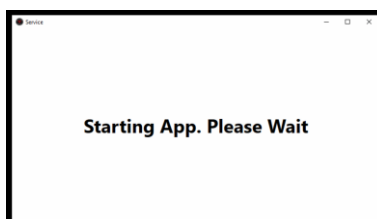

Mounting Kiosk to the Floor

1. From inside the kiosk, find the two oval through holes located at the bottom.

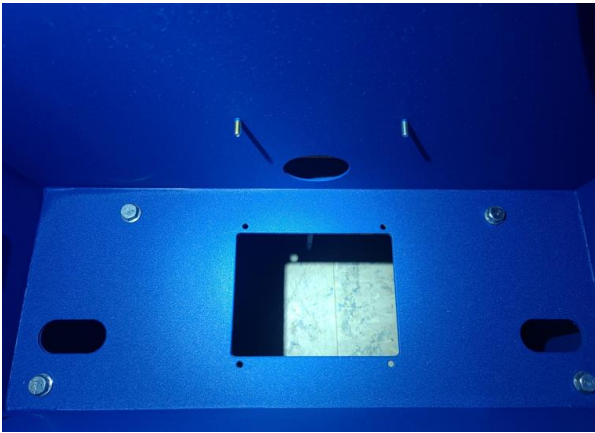

2. From each oval through hole, locate the floor mounting hole.



1. Drill a hole into the floor using a 5/16" concrete drill bit (not provided).
2. Using a 5/16" concrete anchor (not provided), fasten the kiosk to the floor.
3. Repeat on the other side.

Credit Card Device

The credit card device that comes mounted on the kiosk will need to be configured by Amusement Connect support once the kiosk is installed and active. However, it is the customer/operator's responsibility to fill out and return all necessary documentation for processing authorization.

Enabling Credit Card Device

1. Log into kiosk.
2. Enable/disable the Credit Card device.
 - a. Check/Uncheck box next to Bill Validator –Checked (Enabled) is the Default.

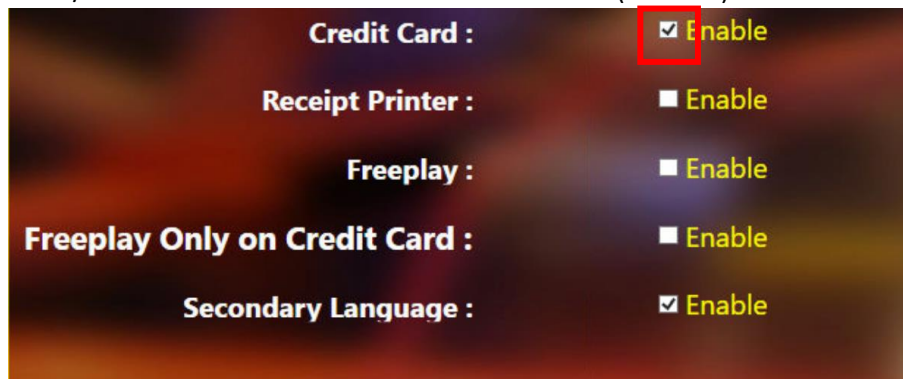

- b. Click Save.
- c. At setting saved successfully prompt, click OK.

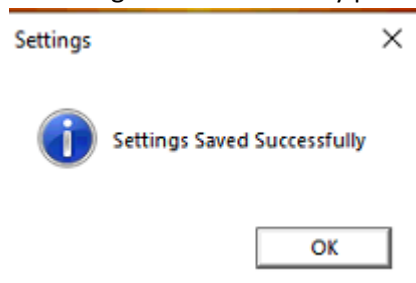

- d. Click Cancel to return to Kiosk Start Screen.

Alert Eruption

If the credit card device displays “Alert Eruption” on its screen, this is an indication that the tamper resistant software has activated. This condition cannot be repaired in the field and will have to be replaced. This condition is not covered under warranty.

Cleaning

1. Unplug all the wires from the terminal.
2. Use a soft cloth that is very slightly soaked with soapy water to clean the outside of the terminal.
3. Do not clean the electrical connections.
4. Do not use in any case, solvents, detergents or abrasive products: Those materials might damage the plastic or electrical contacts.
5. Avoid exposing the terminal to the direct rays of the sun.
6. Do not put anything into the slot of the smart card reader.
7. Plug the device back in.

Card Dispenser

Loading

RFID cards can be loaded into the card dispenser stack in any direction. Recycled cards do not need their values cleared before placing back in the kiosk.

Note – Do not place cards on top of the card dispenser weight or cards will not vend.

Testing

1. Enter Kiosk Settings by tapping the Software Version (V5.X.X.XX) on top right side of screen 11 times.
2. Enter the Kiosk Password, which is “kiosk@846” by default. If unsure, Login into the WebApp>Location Wizard>Select Location>Click “Kiosks”>Find Kiosk Password on the right.
3. Tap on the “Test Card Dispenser” button near the bottom center of the screen.

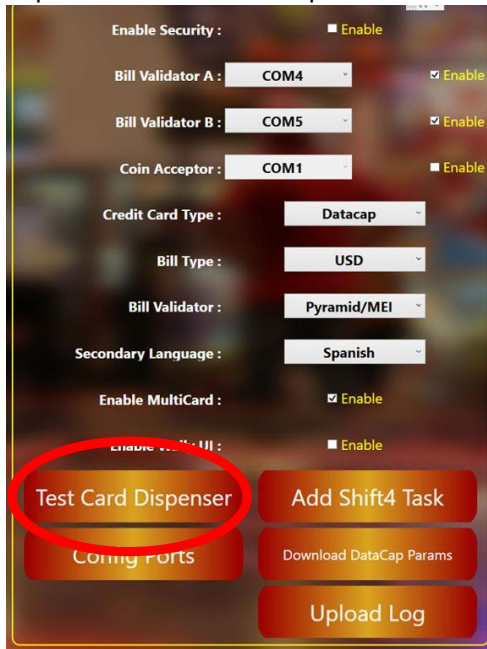

4. Once pressed, the Card Dispenser command screen will appear with the following options
 - a. Read – Reads the card number of the most current card ready to be dispensed.
 - b. Front Hold – Moves a card to the front of the dispenser and holds it. Card will be partially sticking out of the dispenser.
 - c. Dispense – Card is fully pushed out of the card dispenser.
 - d. Error Bin – Moves a card to the error bin which is located at the back of the dispenser underneath the card tower.
 - e. Close – Closes the screen.



Maintenance

If the card dispenser has dispensed 50,000 cards or has been in service for 5 months the following maintenance is recommended.

1. Wipe the rubbing wheel in the bottom of dispenser, rubber roller in card dispensing channel, and IC contact with soft cloth with alcohol to clear foreign materials.
 - a. A cleaning pad (SuzoHapp P/N 29-1167-00) can also be used in place of the cloth/alcohol.
2. Clean sensors in card dispensing channel with a small brush or dust blower.
3. Check the tightness and wear of belts to do adjustment or change if needed.
4. Double check the light (red or blue) on the card dispenser circuit board is illuminated to ensure power to the device.

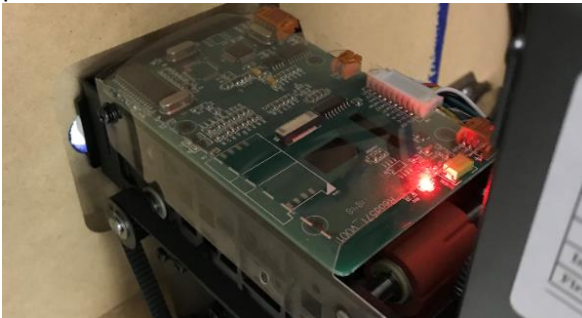

Sensor Cleaning

If the kiosk is ever unable to detect the presence of a card or if it dispenses multiple cards when it is not supposed to, it may be an indication that additional cleaning is required on the card presence sensors.

1. Power down the kiosk.
2. Locate the sensor circuit board on the side of the card dispenser.
 - a. The card dispenser may need to be removed from the kiosk to access the sensor circuit board by removing the four mounting screws that hold the dispenser to the kiosk.

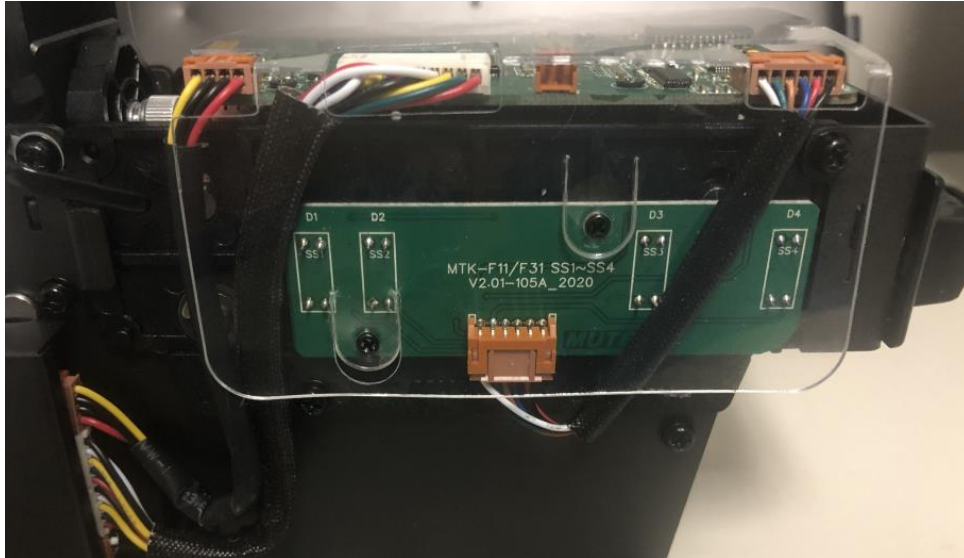

3. Remove the card sensor board mounting board screws.

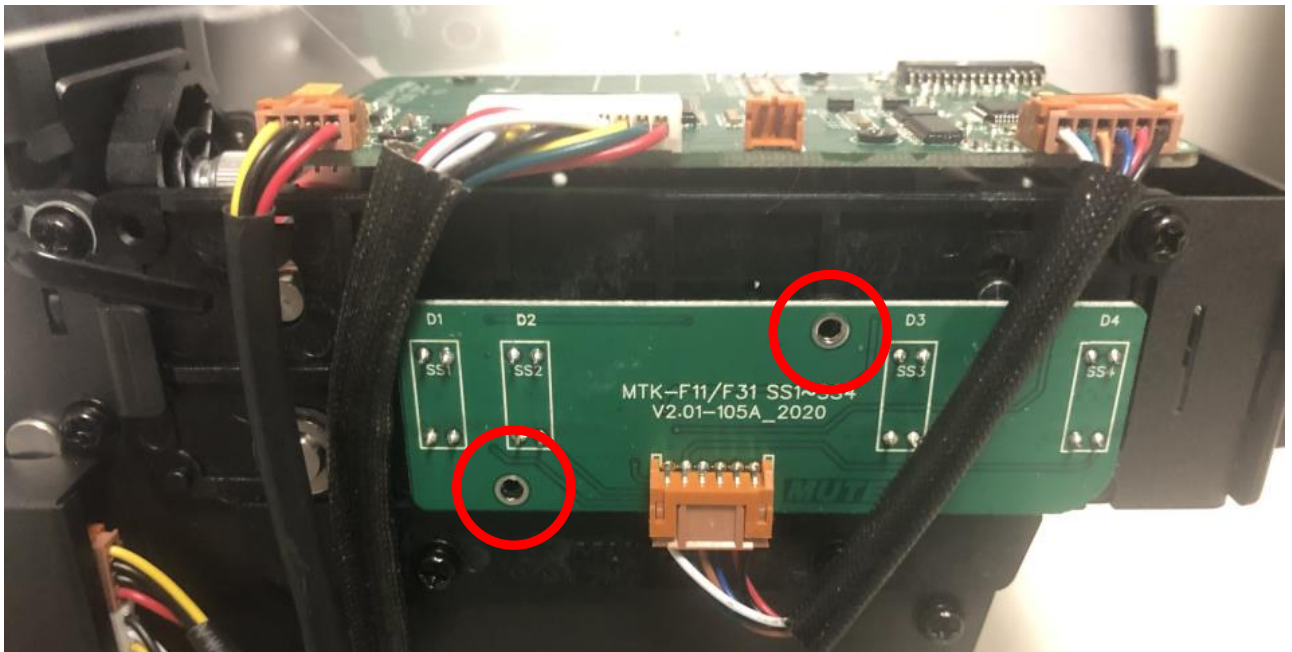

4. Remove the card sensor board to access the sensors. Using alcohol and a soft cloth or cotton swab, lightly clean between the sensors to remove any dirt or debris. Be very careful to not touch any other components on the board.

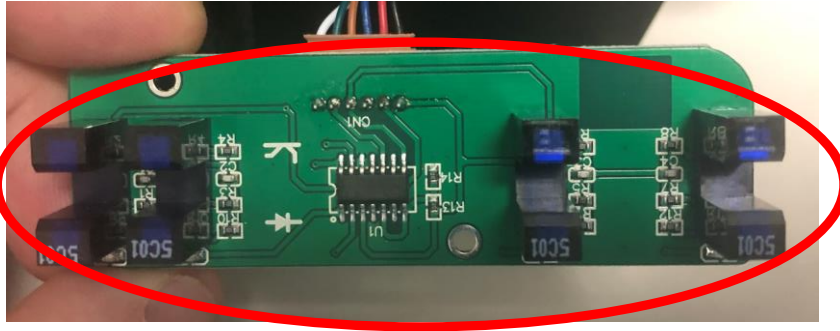

5. Once clean, place the board back in the card dispenser and fasten.
6. Power the kiosk back on.
7. Test the card dispenser.

Adjusting the Card Thickness Gauge

There are several different card thickness adjustment knob types (with locking screw, without locking screw) but they all work under the same principle.

Without locking screw

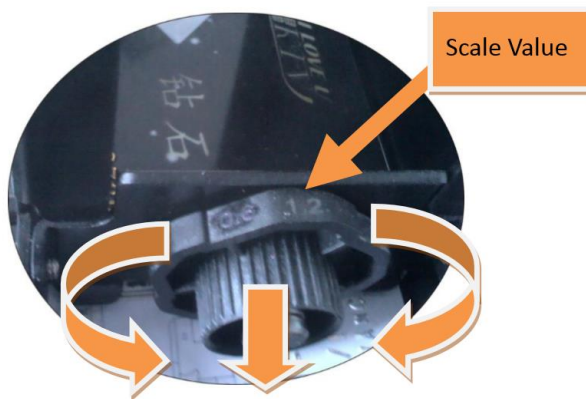

1. Pull out the turn-knob lightly (approx. 1.5mm) and turn the knob clockwise or counter clockwise to the scale value of dispensing card thickness.
2. Release the knob.
3. Test the card dispenser to determine if the proper thickness has been set.

With locking screw

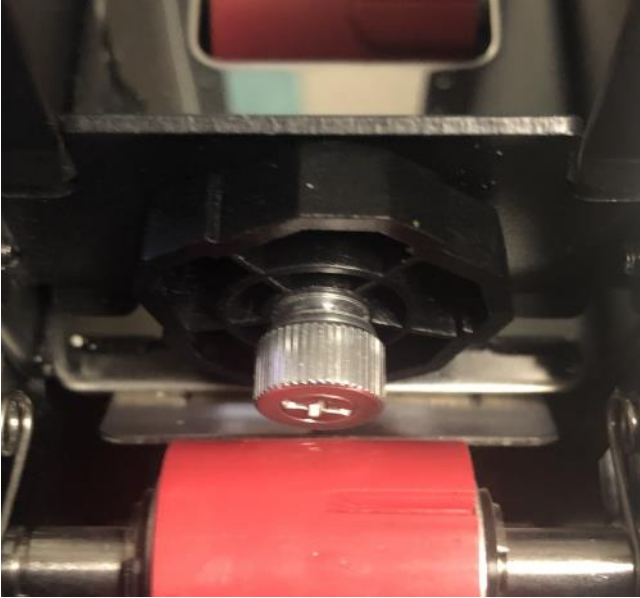

1. Loosen the locking screw without fully removing it from the dispenser.
2. Pull out the turn-knob lightly (approx. 1.5mm) and turn the knob clockwise or counter clockwise to the scale value of dispensing card thickness.
3. Test the card dispenser to determine if the proper thickness has been set.
4. Once adjusted, tighten the locking screw.

Adjusting the Card Dispenser Belt

If the triangular shaped belt on the right hand side of the card dispenser feels loose, there are steps to get it tightened up.

2. Locate the drive belts on the side of the card dispenser.

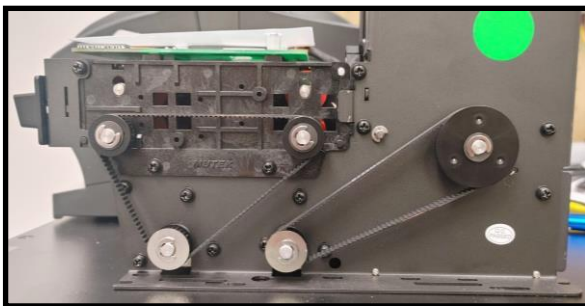

3. Loosen all the screws highlighted.

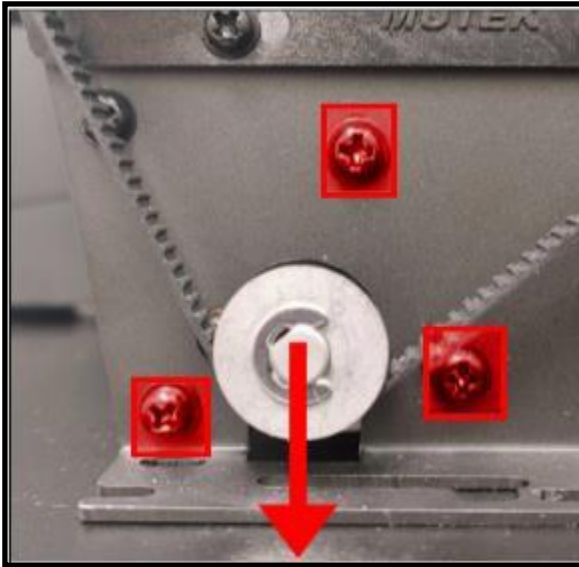

4. Once loose, pull downward on the bottom most motor until the belt is tight.
5. While holding the motor in this tighter position, re-tighten the highlighted screws

RFID Card Scanner

The RFID scanner in the kiosk is the same make and model as the RFID keyboard wedge used to scan cards/create special cards, which is included in most Amusement Connect system purchases. When the device is powered on, a red light is visible through the plastic housing on the front of the kiosk.

Testing RFID Card Scanner

1. Log into the kiosk.
2. Touch “Close App” under the Operations section.
3. At the desktop, open the On-screen Keyboard by touching the keyboard icon located at the bottom right corner of the screen.
 - a. For more information please see the Finding the On-Screen Keyboard section.
4. Type “Notepad” until the Notepad application appears.
5. Touch the Notepad application to start.
6. With Notepad open, scan a card. If a 10 digit number is displayed, the RFID Card Scanner is working properly.
7. If anything other than the 10 digit number is displayed, configure the RFID scanner.

Configuring the RFID Card Scanner

1. Plug RFID Scanner into PC
2. Navigate to C:/Kiosk Tools/RFID Scanner
3. Click on Demo

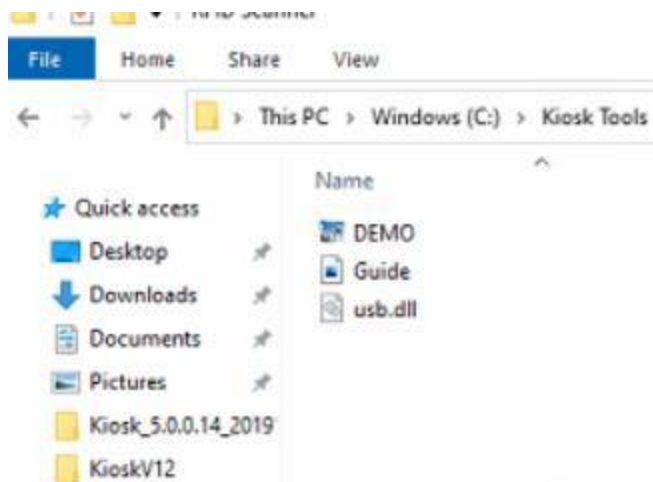

4. With Demo.exe open-> Confirm 10 no. in D(four byte) is Selected->Select add “Enter”->Click Set...if successful you should see Set Up Success

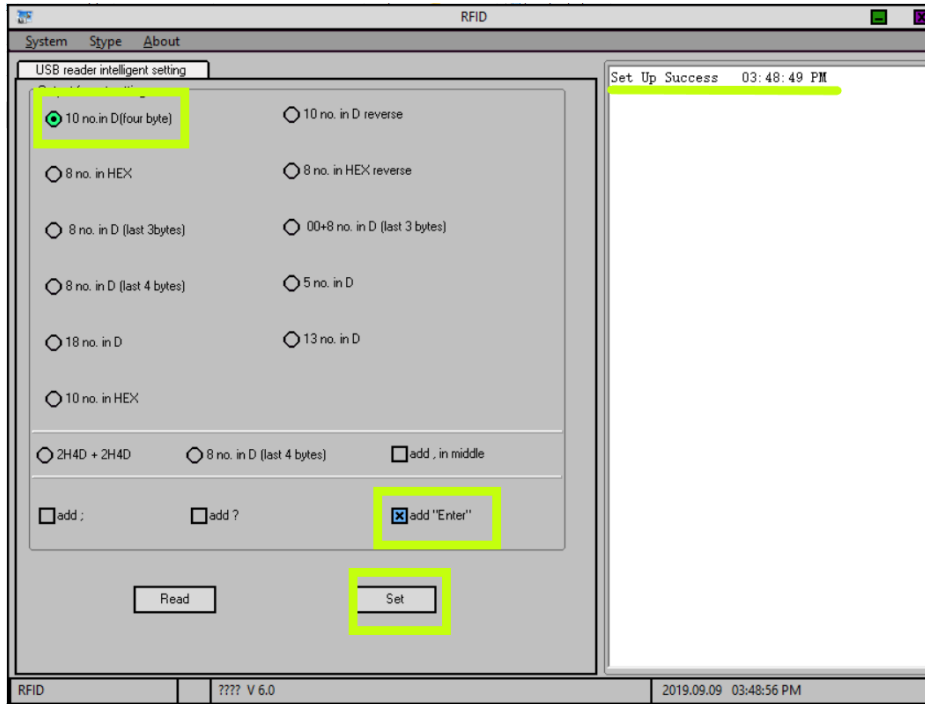

- a. If message other than success appears, check that the RFID scanner is plugged in on both ends.
5. Close application and open kiosk app.

Bill Validator

Enable Bill Validators

3. Log into kiosk.
4. Enable/disable Bill Validator.
 - a. Check/Uncheck box next to Bill Validator –Checked (Enabled) is the Default.



- b. Click Save.
 - c. At setting saved successfully prompt, click OK.

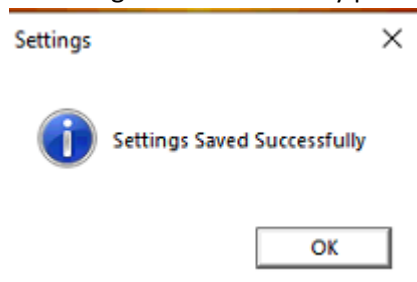

- d. Click Cancel to return to Kiosk Start Screen.

Pyramid Configuration Card

A copy of the Pyramid Configuration Card can be found at the end of this manual. The card should be filled out using the following configuration (\$1-\$20) acceptance.

**INSERT THIS SIDE UP, THIS END FIRST
USE BLACK INK, FILL OVALS COMPLETELY**

Pulse/Serial \$1/\$5 Credit Lines

MDB \$1-\$20 Credit Lines

RS-232 Always Enabled

Parallel Hi

Special 1 Special 2

section 1

Select only one Interface Type

64 4

32 2

16 1

8 None

section 2

Pulses per Dollar (sum of selected values)

Example: For 50 ppd, fill in the ovals for 32, 16, and 2, (32+16+2 = 50)

Pulse Speed: Slow Fast

Lighted Bezel: Solid On Flashing

section 3

Bill 1 (\$1) Bill 2 (\$5)

Bill 3 (\$10) Bill 4 (\$20)

Bill 5 (\$50) Bill 6 (\$100)

Bill 7 Bill 8

Bill 9 Bill 10

Bill 11 Bill 12

section 4

Select Bills to Enable

Example: To accept USA \$1, \$5, and \$10, fill in the ovals for Bill 1, Bill 2, and Bill 3.

Security Level: High Low

Insert Direction: Face up, Left 1st All 4 Ways

section 5

This Configuration Card should be printed on standard copy paper, measuring 6.0 x 2.6 inches (152 x 66 mm).

If printing from a .PDF file, turn off the "shrink to fit" option in your printer settings for proper scale.



CURRENCY VALIDATION EXPERTS

Note – When printing a configuration card, please set scaling to “none.”

Configuring Pyramid Validator

1. Print a copy of the Configuration Card with the scaling off – when cut, the card needs to be the size of a dollar bill
2. Fill in the ovals in each section as described below, using black ink:
 - a. Section 1: RS232
 - b. Section 2: fill in none
 - c. Section 3: Flashing
 - d. Section 4: Bill 1, Bill 2, Bill 3, Bill 4, Bill 5, Bill 6
 - i. Only fill in Bill 5 and Bill 6 if model takes \$50/\$100s
 - e. Section 5: Low, all 4 ways

3. Configure the Bill Validator
 - a. Hold the diagnostic button for 10s
 - b. After lights flash 10x, insert card
 - c. Validator will pull card in, then spit it back out
 - d. Validator will power cycle and stack.
 - e. A video on this process can be found at:
<https://youtu.be/Jm1GmwVy9SQ>

Configuring Pyramid Validator - Canadian

1. Print a copy of the Configuration Card with the scaling off – when cut, the card needs to be the size of a dollar bill
2. Fill in the ovals in each section as described below, using black ink:
 - a. Section 1: RS232
 - b. Section 2: fill in oval next to None
 - c. Section 3: Flashing
 - d. Section 4: Bill 1, Bill 2, Bill 3, Bill 4
 - e. Section 5: Low, Face Up, left
3. Configure the Bill Validator
 - a. Hold the diagnostic button for 10s
 - b. After lights flash 10x, insert card
 - c. Validator will pull card in, then spit it back out
 - d. Validator will power cycle and stack.
 - e. A video on this process can be found at:
<https://youtu.be/Jm1GmwVy9SQ>

Cleaning and Care - Abridged

Required Equipment, Tools and Supplies

Description	Part Number
Microfiber cleaning cloth	N/A
Canned air	N/A
Small brush	N/A
50/50 IPA & water spray bottle	N/A

- Remove cash box, clean plastic ball bearings on either side of the cash box face with damp, lint-free cloth.
- Remove black I/O connector from side of Bill Validator and remove black bill path plate (left image). Clean sensors and roller with damp, lint-free cloth.

- Above the plate inside the validator (right image), clean sensors with damp, lint-free cloth.

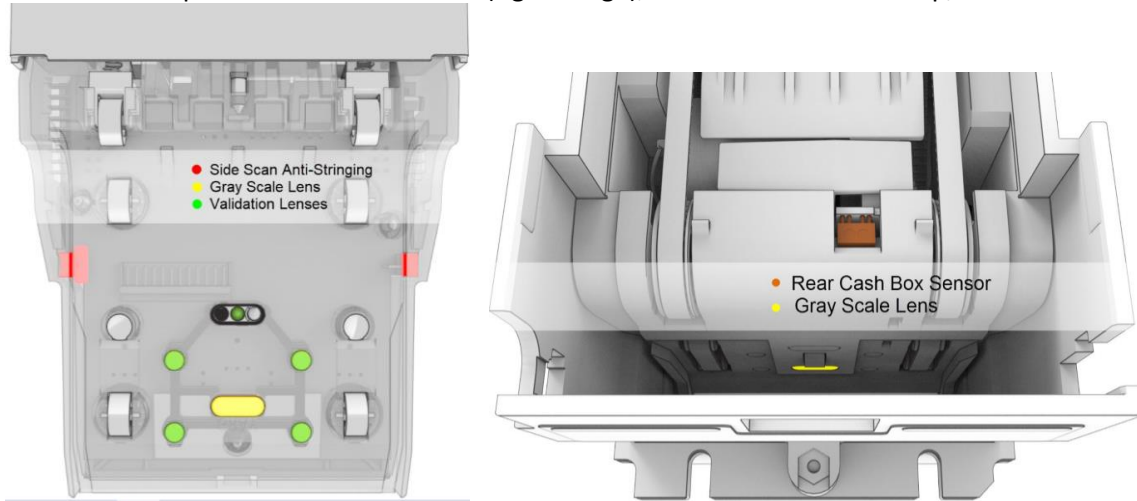

Special Note:

We currently **do not recommend a cleaning card for the bill acceptor at this time. These cards can leave debris behind that can and will cause further issues if used.

****NEVER USE OILS OR SILICON SPRAY ON THE ACCEPTOR****

**Before proceeding with these cleaning instructions please disconnect all power and I/O connections from the validator before starting.

Bill Acceptor Not Lighting Up or Powering On

1. Check to see that the bill validators are enabled on the kiosk setting screen.
2. Open the kiosk and ensure that the power cables for the bill validator are properly seated (reference the Kiosk Device and Cabling Coloring Code section in this manual).
3. Unplug the suspect device from the power strip and then plug back in.

Bill Acceptor Not Taking Bills

1. Check to see that the bill validators are enabled on the kiosk setting screen.

2. Check to see that the cash box is properly seated.

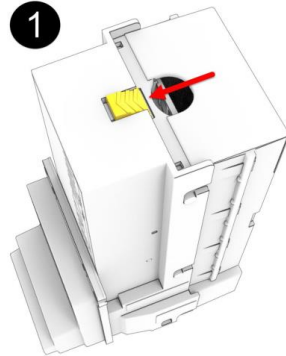

3. Remove the bill box and ensure nothing is jammed in the bill path.
4. Check to see that the two white plastic ball bearings on the bill box are clean and freely move.

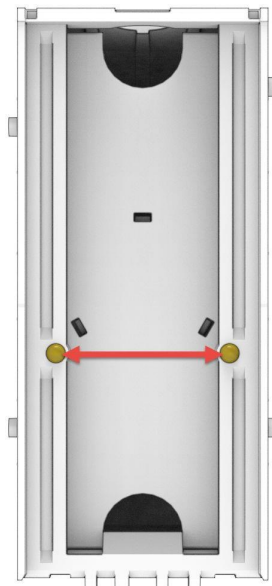

5. Remove the bill path follow plate (located at the bottom on the bill validator) and ensure nothing is jammed in the bill path.
6. Replace all components and test Bill Validator.

Cleaning and Care - Full

Required Equipment, Tools and Supplies

Description	Part Number
Microfiber cleaning cloth	N/A
Canned air	N/A
Small brush	N/A

50/50 IPA & water spray bottle

N/A

Cleaning Instructions

Step 1: Remove the cash box from the unit being serviced as instructed below:

1. Depress the cash box latch by pulling it towards the front of the bill acceptor.
2. With the latch depressed slide the cash box up.
3. Now with the cash box slid up you can remove by pulling it out away from the validator.

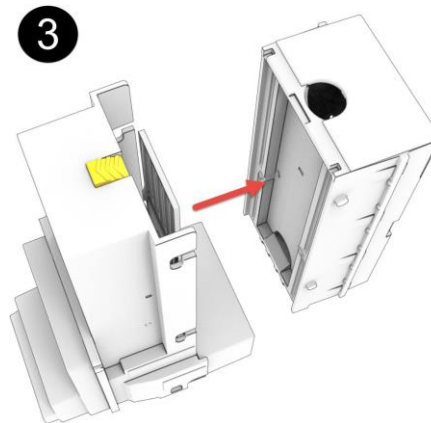
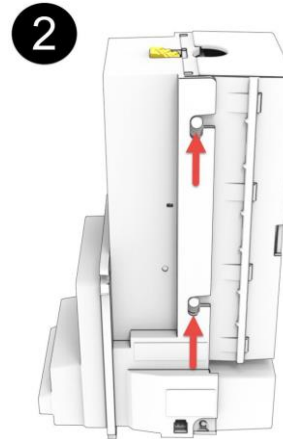
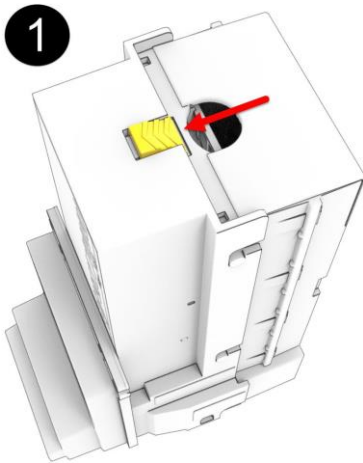

Step 2: With the cash box removed locate the two white plastic ball bearings located on the face of the cash box pointed in towards the validator when installed. There is one bearing on each side of the plastic frame. These plastic ball bearings can get fouled with lint, paper, dust and dirt. Clean if any is present as this can cause the bearings to not make full contact with the bill or completely stop it from moving.

Please see below for further identification and detailed instructions.

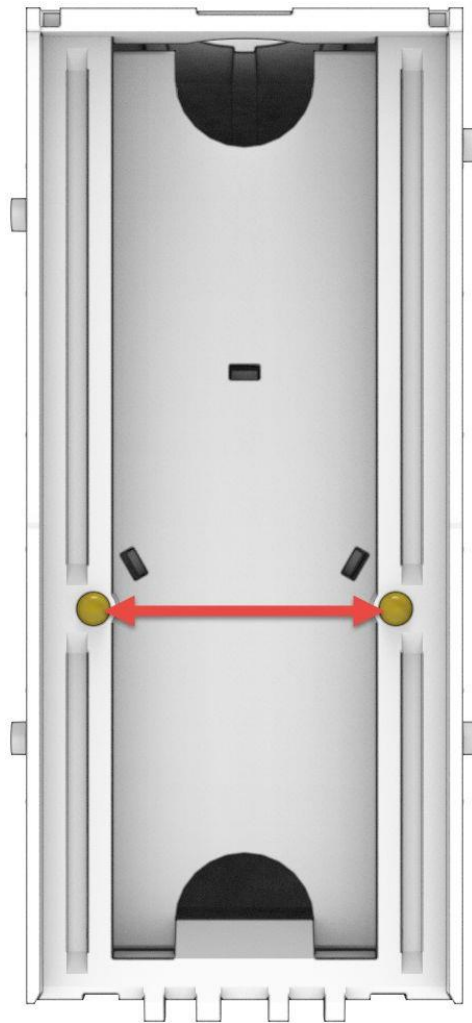

This kind of condition will create bill jams, possibly leaving the bottom of a bill slightly outside of the cash box and not fully stacked. Dampen a lint free cloth with water (only enough water to pick up dust) and run the cloth up and down over the bearings until all debris is cleared.

If it is found to have a depressed ball and was not solved by the cleaning it will need to be replaced as this can cause a jam in the cash box.



Step 3: Bill path plate cleaning

We recommend disconnecting all power and I/O connectors from the validator at this point. If any side connectors are still installed this could prevent you from fully removing the bottom plate without causing any damage to the validator.

No tools are required to pull the bill path plate out. There is a recessed latch that must be pushed in to release the plate. While pushing the latch in with your thumb, pull the plate straight back out of the main frame of the bill acceptor as seen in the image below.

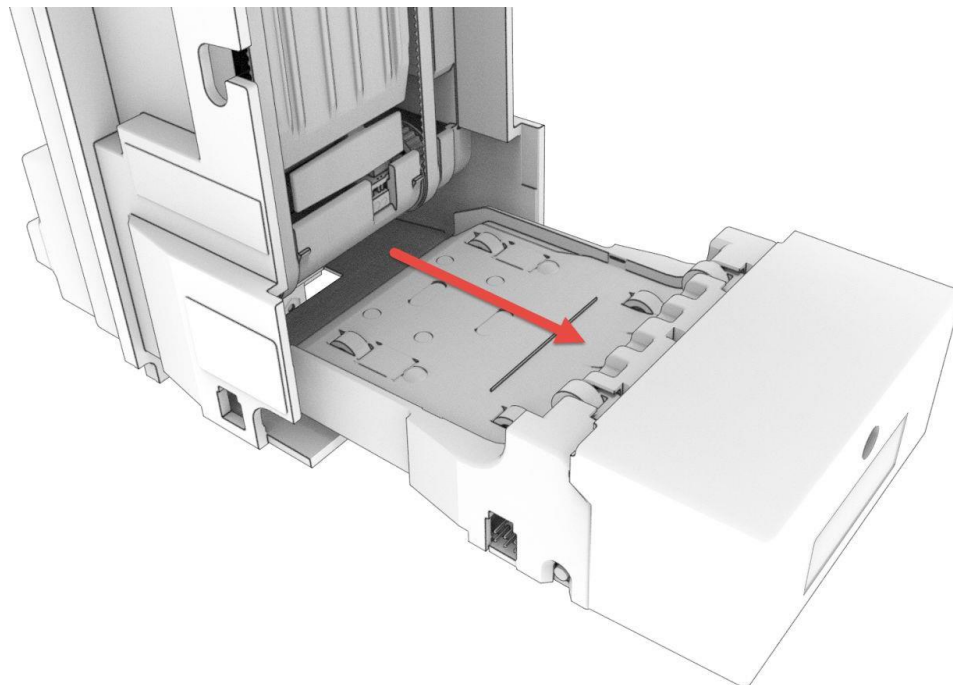
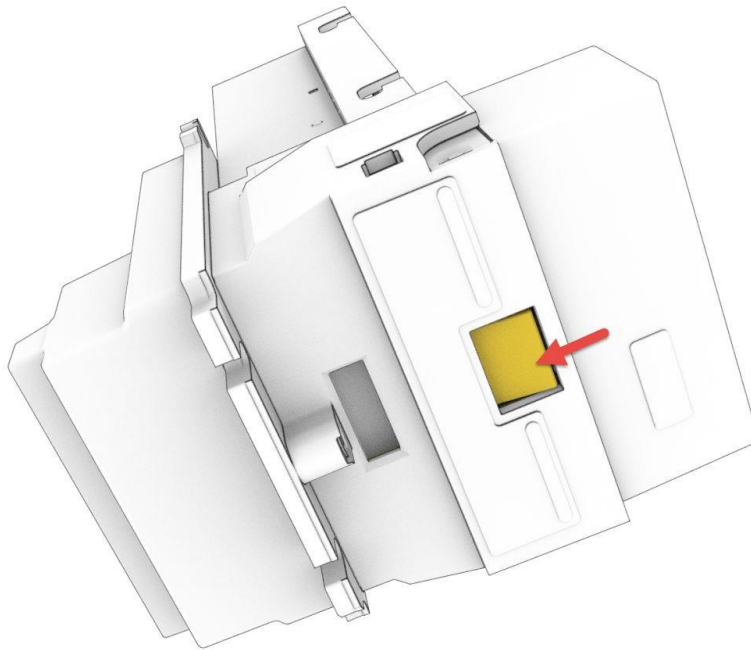

Step 4: Once the plate is fully removed you will have full access to all the validation and side scan anti stringing lenses.

Inspect the plate for dust, dirt, smoke and debris. There are four round lenses and two oval lenses in the plate that must be cleaned. Dampen a lint free cloth with water, only enough water to pick up dust. Using the damp cloth wipe it over all lenses and roller until clean.

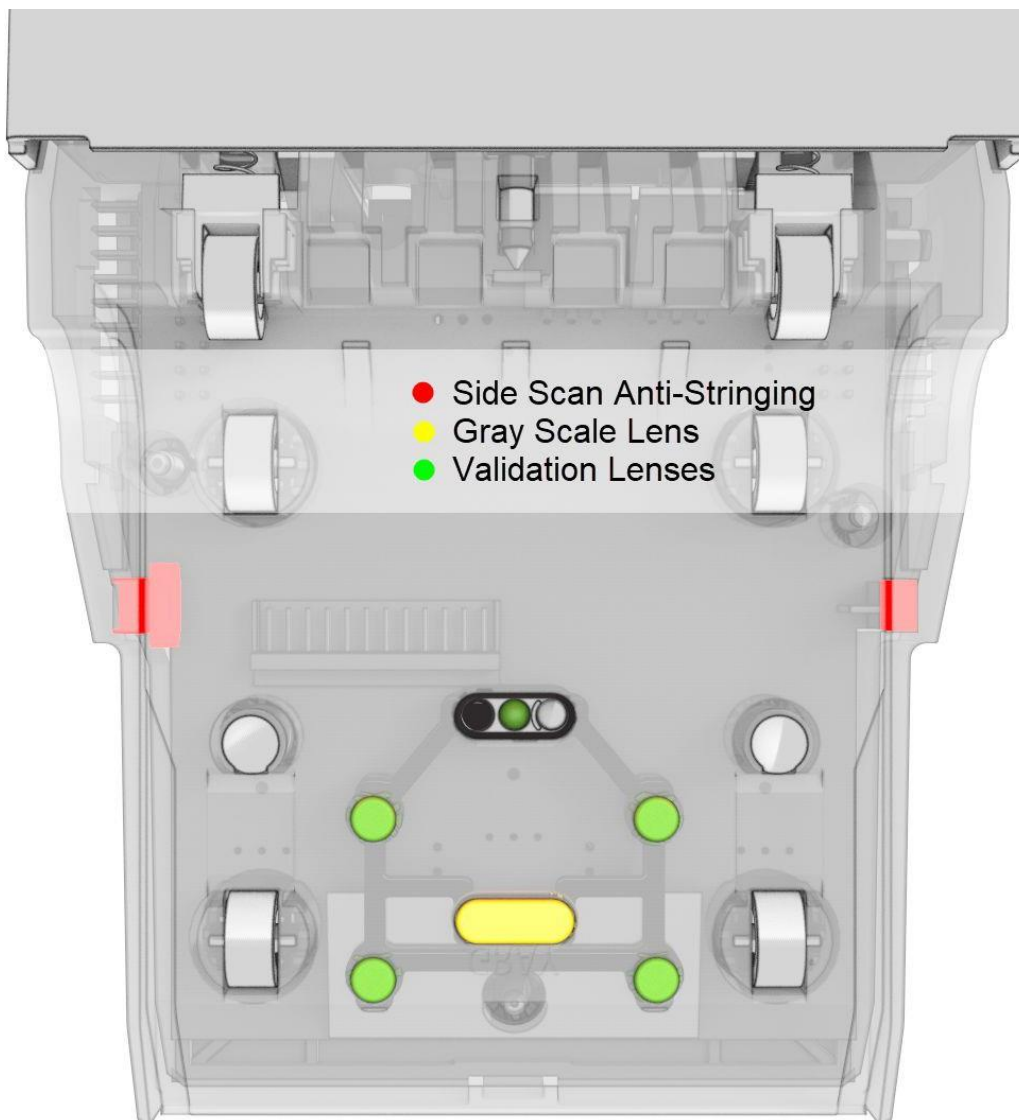

Step 5: Directly above the plate inside the validator, there is another set four round and oval lenses that beam back and forth to each other in the bill path plate as seen in the image below. Dampen a lint free cloth with water, only enough water to pick up dust and run the cloth over all lenses and rollers until clean.

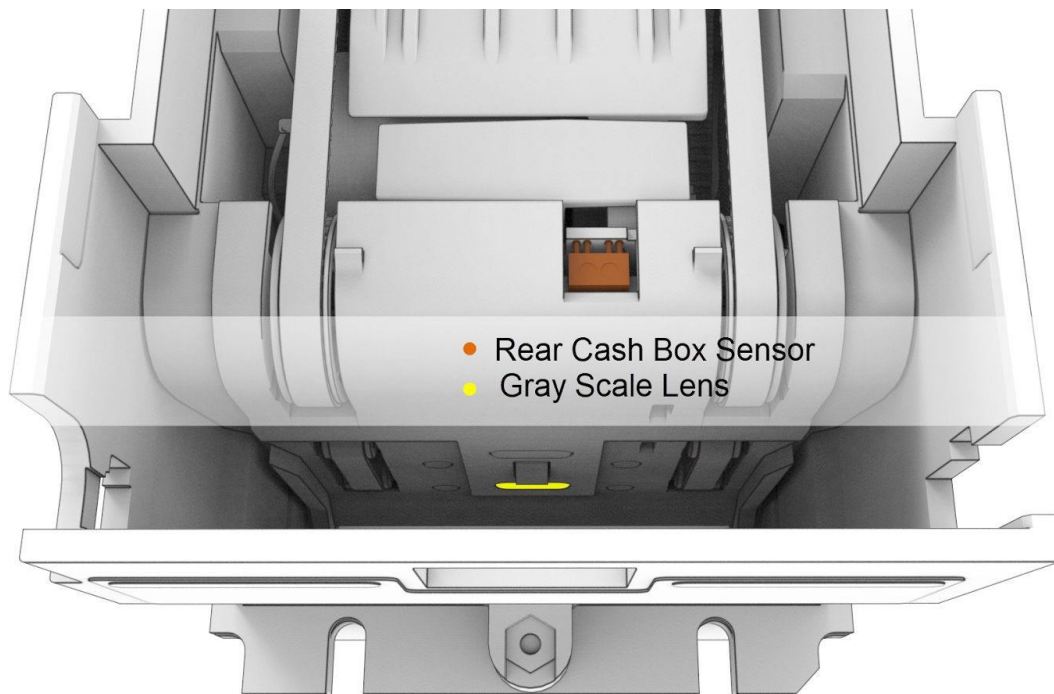

Of Special Note: Sidescan, grey lenses and cash box sensor

Use the images below to locate the side scan anti stringing, grey lenses and cash box sensor. Be sure to keep these lenses clean and debris free. If smoke or dirt builds up in these areas, bill acceptance and performance will lower and bill rejects will become more frequent. In certain cases water may not be enough to clean the surfaces. We recommend a 50/50 alcohol and water solution. This solution can also be used to clean the drive belts if they are extremely dirty.

****NEVER USE OILS OR SILICON SPRAY ON THE ACCEPTOR****



Troubleshooting

Kiosk will not turn on	Kiosk not plugged into wall	Plug in kiosk. Check outlet.
	Power switch on back of kiosk is off	Turn on switch.
	Power strip inside kiosk is off	Turn on power strip.
	PC inside kiosk is off	Turn on PC.
	CMOS battery inside PC is dead	Change CMOS. Contact Parts and Shipping (ext 3) if a CMOS battery is needed.
Card dispenser not dispensing cards	No power to dispenser	Check for red or blue light on the main board of the card dispenser. If no light, check the power connections to the dispenser.
	No communication to the dispenser / device not connected	Check orange connections on the back of the kiosk.
		Go to kiosk settings and press "Config Ports" button to see if dispenser is connected to kiosk. Verify correct Com port is selected for dispenser. If not found, contact support.
	USB port issue	Move USB to cable to different port. If currently on the USB hub, move to a PC USB port. If on the PC, move to the USB hub.
	Out of cards	Load cards into the dispenser.
	Cards jammed/blocked	Ensure card weight is not blocking path.
		Fan out cards in dispenser stack to eliminate any static build up.
		Ensure cards are not sticky/dirty from reuse.
		Remove jammed card.
		Run dispenser test program from kiosk setting screen and move cards out or to the error bin.
	Drive belts loose	Adjust the dispenser belts.
Card dispenser dispensing too many cards	Dispenser thickness gauge loose	Adjust card thickness gauge.
	Card presence sensors blocked	Clean sensors.

Credit card device not working	Device not activated	Ensure all paperwork returned to processor.
	Device not enabled	Log into kiosk settings screen and enable device.
	Alert Eruption	Contact support.
RFID card scanner not reading card	No power to scanner	Check for red light to verify power. Check connections.
	Not reading data	Exit to desktop and open note pad. Test scanner and configure card scanner.
Bill Validator not turning on	No power to device	Check power connection inside kiosk
		If kiosk has dual BVs, swap cables to determine if there is a defective cable.
	No communication to the dispenser / device not connected	Go to kiosk settings and press "Config Ports" button to see if dispenser is connected to kiosk. Verify correct Com port is selected for dispenser. If not found, contact support.
	USB port issue	Move USB to cable to different port. If currently on the USB hub, move to a PC USB port. If on the PC, move to the USB hub.
	Device not enabled	Log into kiosk settings screen and enable device.
Bill Validator not accepting bills	Bill validator is dirty	Clean bill validator. See cleaning section in manual.
	Bill jammed	Remove cash box and/or bill path plate.
	Bill validator cash box or bill path plate not seated	Reseat components.
	Bill validator not configured	See configuring Bill Validator section in manual.